

מכרז 35/2022

**דרישות ומפרטים טכניים לתאורה והגברה**

**עבור ההופעה של שירי מימון**

מפרט תאורה סט טיים קוד שירי להקה וינוד :

mega point 12

point 12

aura/ alfa zoom 12

101 12

4light 4

q7 8

bar nsp 2

matrix led 8

follow 1800 1

grand ma2 light 1

viper smoke 2

2 fan

טראס אחורי

5 טראס 4מ

4 צינורות 4מ

6 הנמכות 1 Tמ

פסי לד של ההפקה

סטריפים מסכי לד:

54 קוביות 50/50 פיץ 3

(תוספת סטריפים לטראס 30 קוביות)

פודיום תופים 240/240/20

פודיום קלידים 240/120/20

פודיום dj 180/120/40



פרימן עמית

[freemanamit@gmail.com](mailto:freemanamit@gmail.com)

0528-284787

Handwritten note: *Hand 150 - 2000 (16:0)*

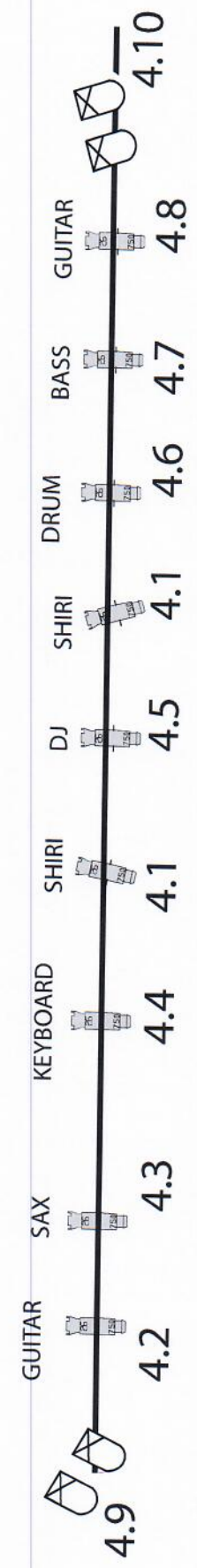
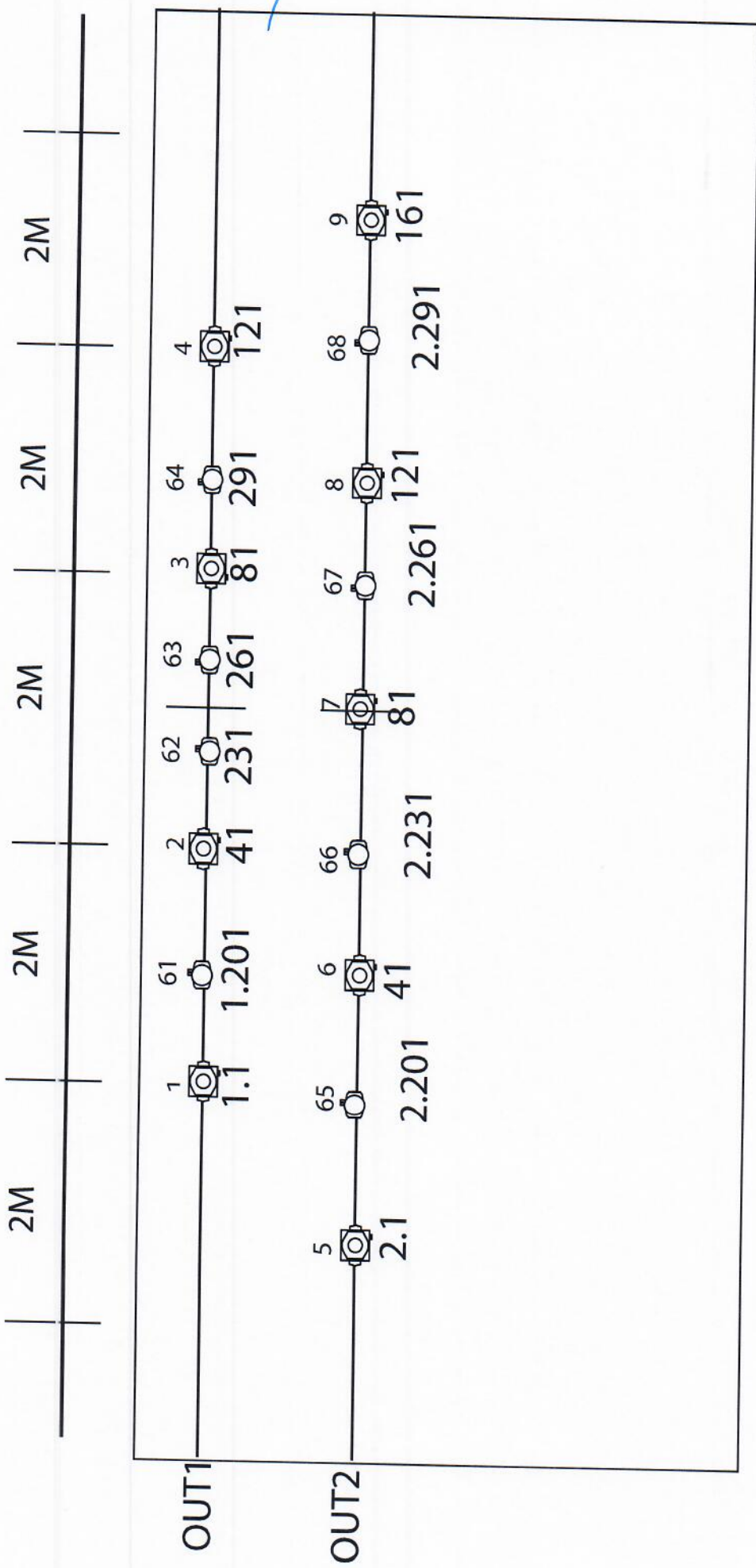



OUT2

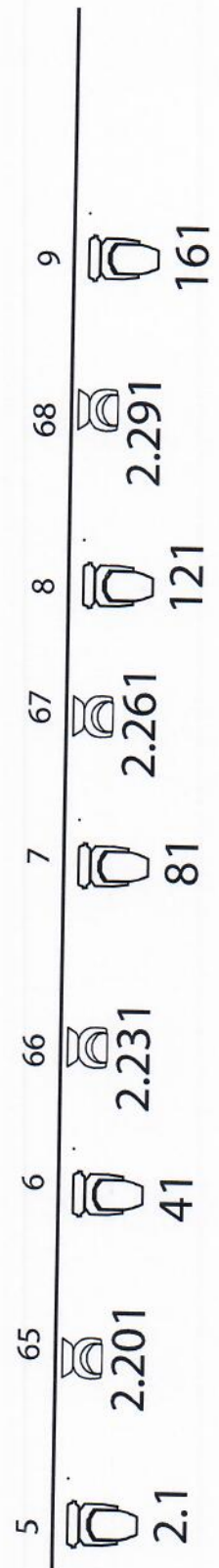

OUT1

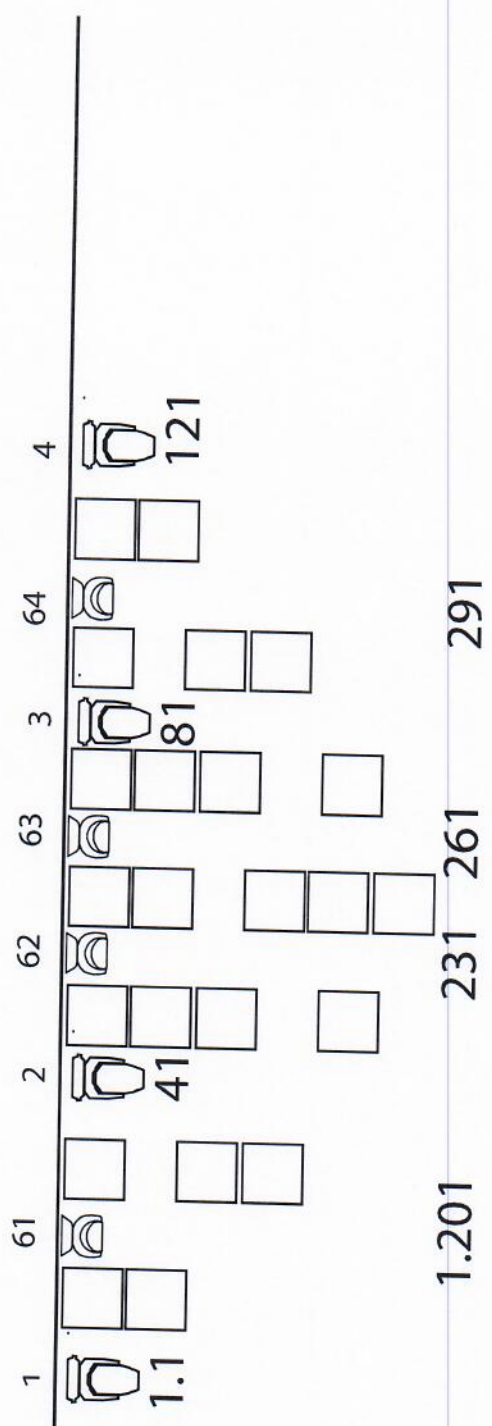

3.501



3.504

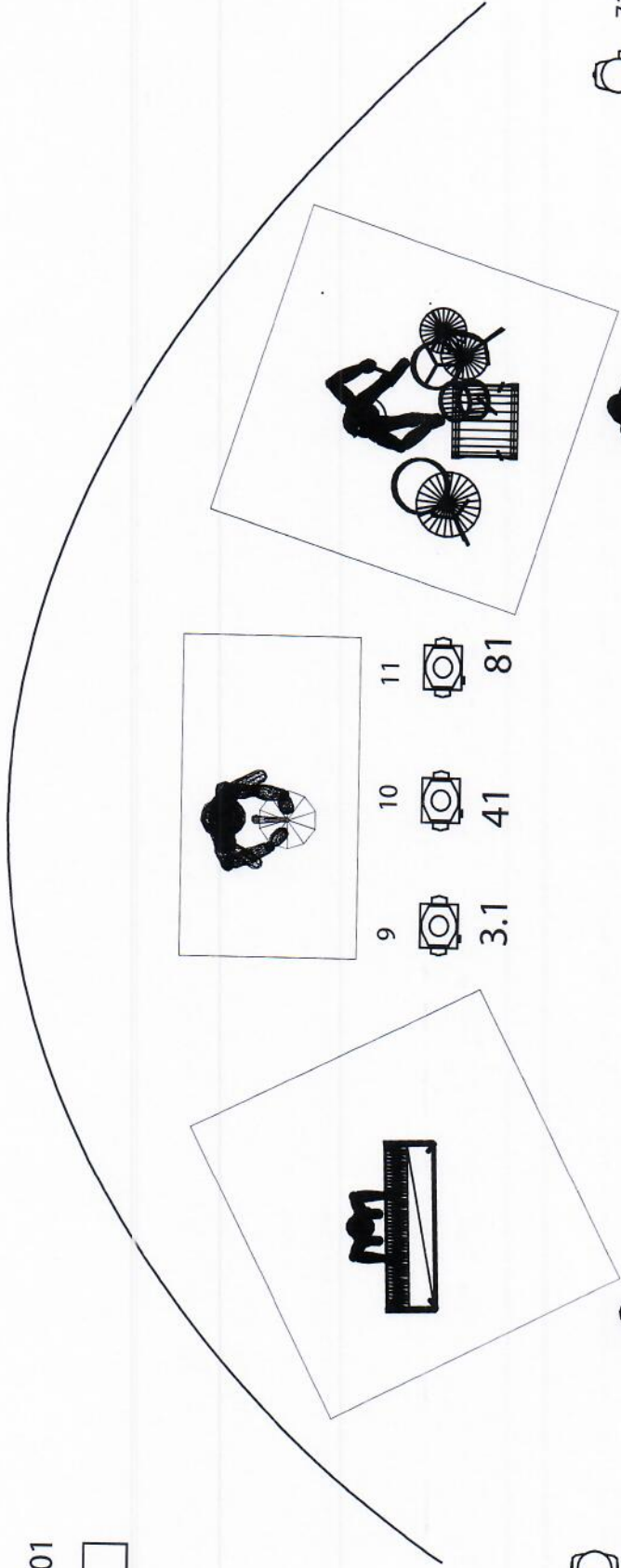

70



3.231

69



3.201

82



3.411

83



3.421

84



3.431

71



3.261

72



3.291

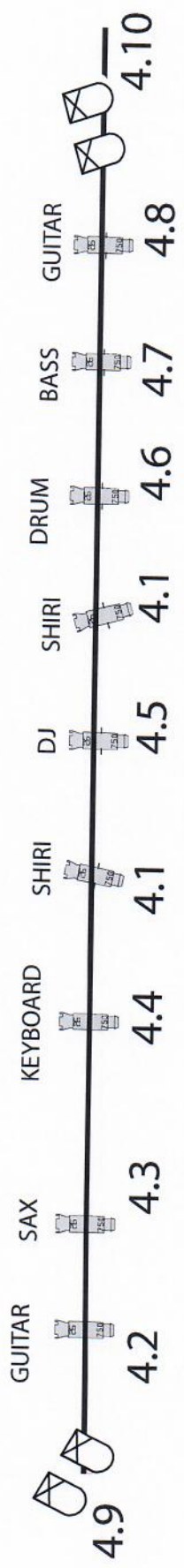

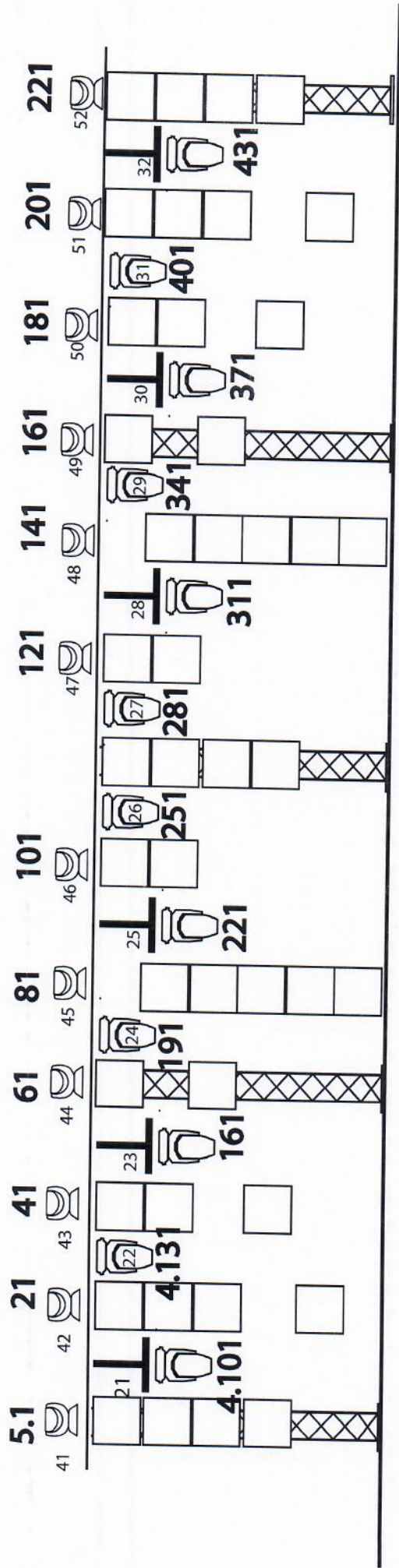

# strip led pixel

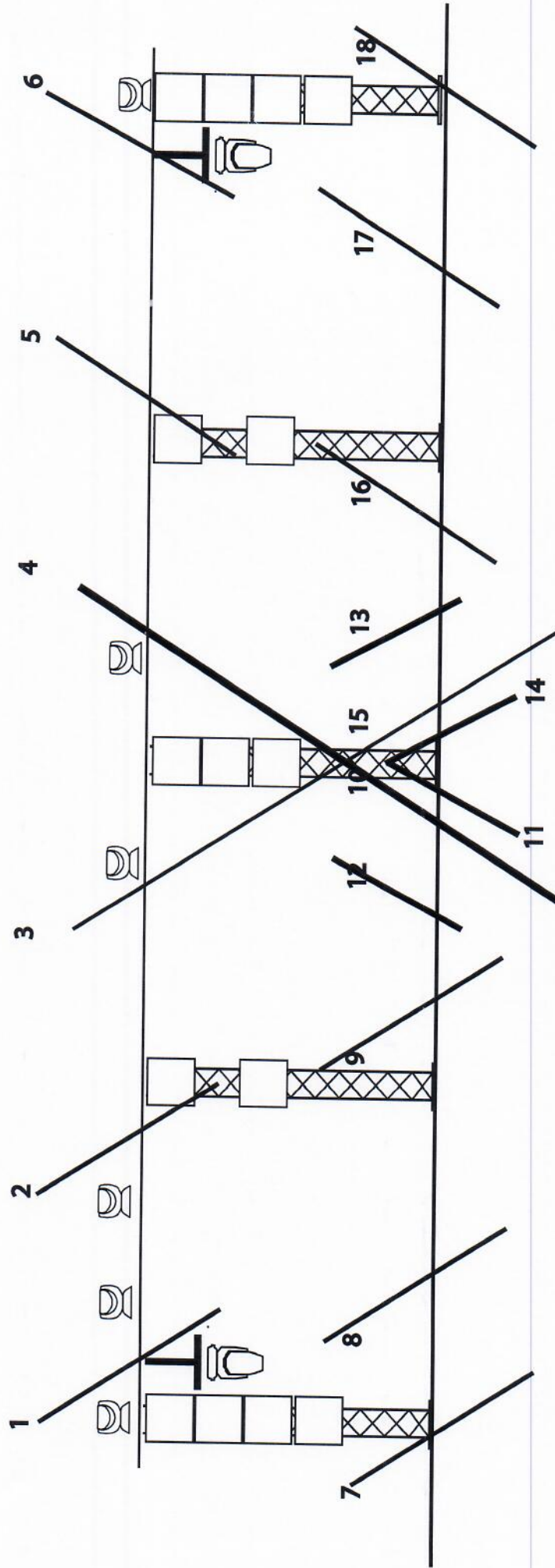

9

$out6 = 1 + 2 + 3$   
 $out7 = 4 + 5 + 6$   
 $7 + 8 + 9 + 10 + 11 + 12 = out8$   
 $13 + 14 + 15 + 16 + 17 + 18 = out9$

כל הזכרים למטה חוץ מה 3 מטר

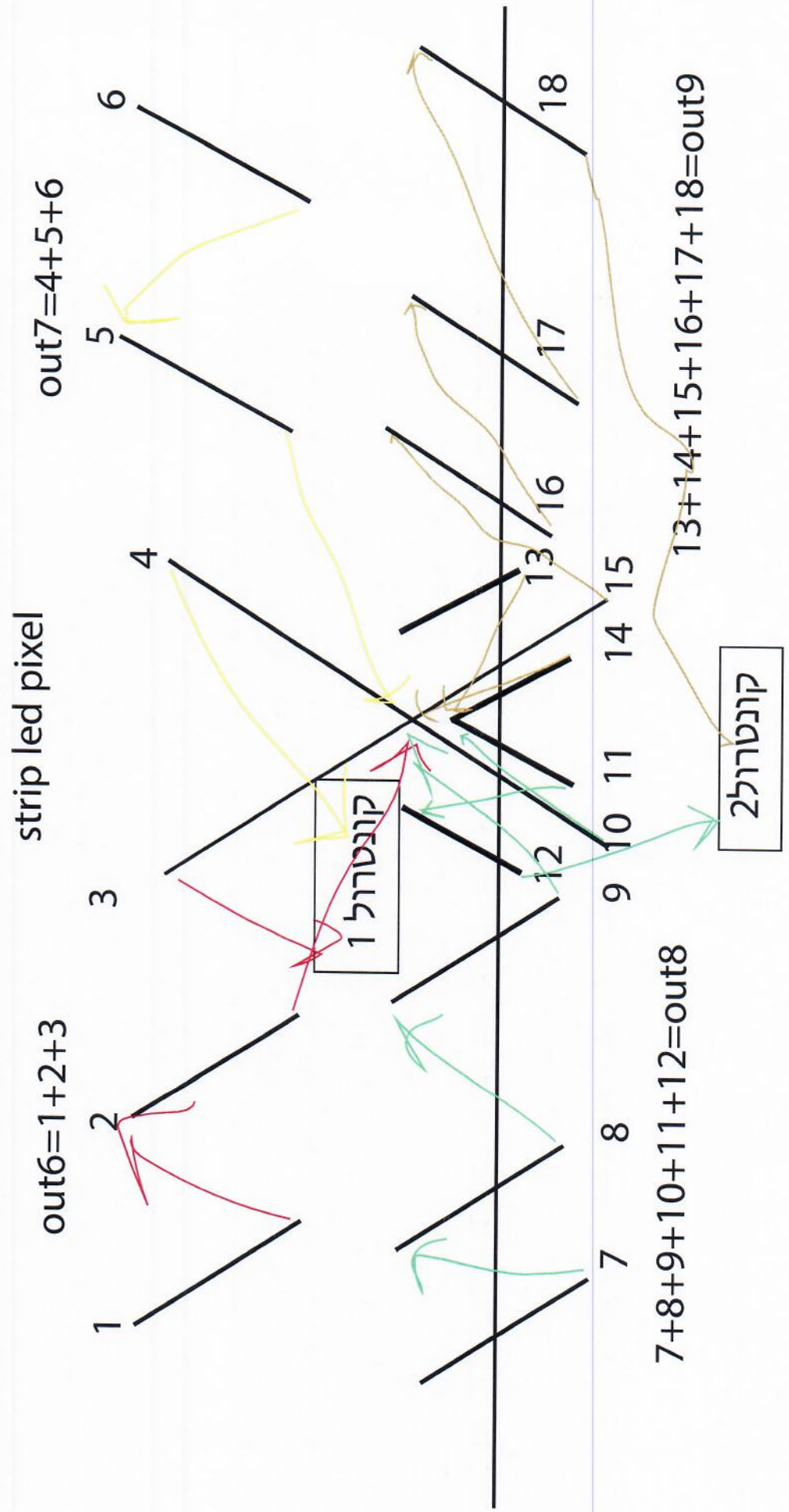

6

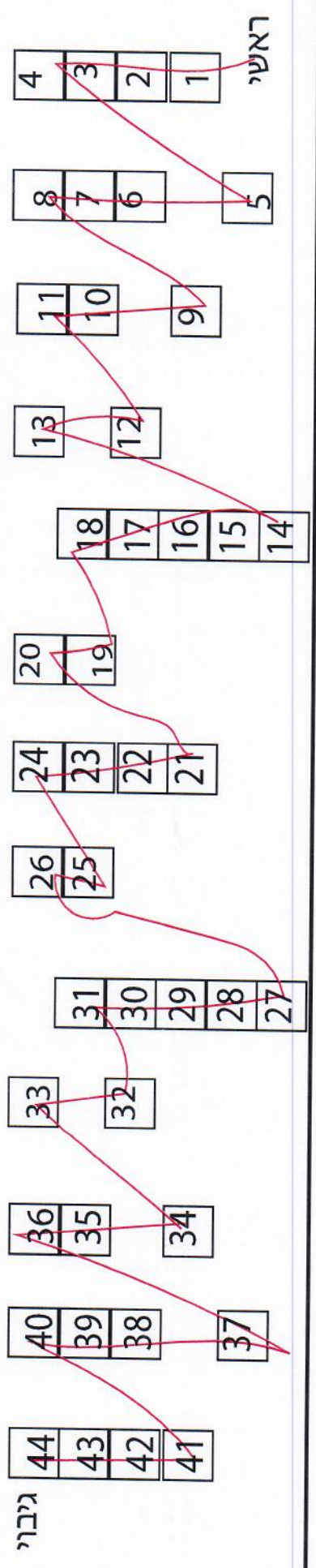
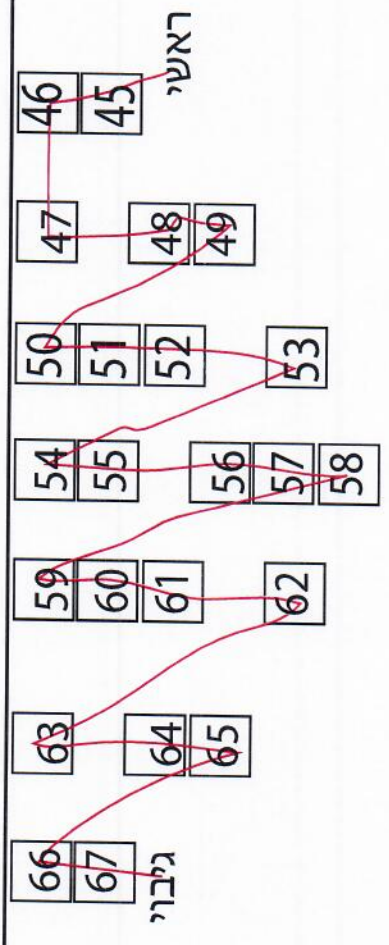

Last Update 26.10.21

**1. FOH:**

Will be located 12-17 meters from stage, middle of the venue off center.

**2. Fa system**

Should be flown or stacked, to maintain an equal coverage of the crowd.  
System must include Front fills, out fills according to audience sitting plot.  
System processor must be controlled from FOH.

**System options:**

Lacoustic - Kiva/Kara/K2 With subs  
Adamson - S10/E12 With subs  
Meyer Sound - Leopard/Melody/Milo with subs

**3. Foh Desk:**

1st: Yamaha CL5  
2nd: Digico SD10

**5. WL Systems:****IEM System:**

- \* 10 X Sennheiser G3 Transmitters w/ 10 Body packs.
- \* Antena Combiner
- \* ENC Cable
- \* Directional Antena (Flag)

**WL Mic's/Guitars/Brass**

- \* 1 X Shure UR1 Body Pack + Adaptor to ATm350/DPA4099/e908 - Sax
- \* 3 X Shure UR4d Receivers (Only UR)
- \* 2 X Shure UR2 Sm58 Hand Held WL Mic
- \* BNC Cable
- \* Directional Antena (Flag)

**6. Stage**

- \* 1 Small mixer for drums mix
- \* 1 Shake Porter Davis for drums
- \* Microphones, Di's & mic stands according to input list.
- \* 2 X Risers :
- \* 2 X 15' wedges (X15/M12/M15...)

**7. Backline**

- \* DR JMS brand: YAMAHA "maple" or "birch" or "recording" custom or" live custom"
- \* Bass drum size:22"X 18"
- \* Tom size" 10"x7" \*12"x8"
- \* Floor size 16"16"
- \* Hardware: yamaha "dfp9500c" bass drum pedal or" dw 9000". yamaha :hs 850/1200 hi hat pedal. 3 boom stands for cym balsa. \*yamaha ds850/ds950 drum throne
- \* KEYBOARD STAND
- \* 2 X GUITAR AMPS -fender twin reverb
- \* BASS AMP-GALLIEN-KRUEGER 2\*12"
- \* 4-music stand with lamp \*1-bar stool \*4- guitar stands\*

## In - Out list

2 of 3

#	Instrument	MIC/DI	Stand	Position
1	BD In	Beta91		Drums - Buki
2	BD Out	D6	Short	
3	Snare Top	D4 / Sm57	Short	
4	Snare Bot	e904	Clip on	
5	HH	Sm81	Long	
6	Tom	e904	Clip on	
7	Floor Tom	e904	Clip on	
8	OH Left	Sm81	Long	
9	OH Right	Sm81	Long	
10	SPD L	Di		Drums - Buki
11	SPD R	Di		
12	Bass	Di		Bass - Danny
13	E Gtr Nitzan	Sm57	Short	Gtr - Nitzan
14	E Gtr Zohar	Sm57	Short	Gtr - Zohar
15	Acc Gt Zohar	Di		
16	Piano L	Di		Yossi - Piano / Mac
17	Piano R	Di		
18	Loop L	Open XLR		
19	Loop R	Open XLR		
20	Harmony L	Open XLR		
21	Harmony R	Open XLR		
22	Solo L	Open XLR		
23	Solo R	Open XLR		
24	Click	Open XLR		
25	Tc	Open XLR		
26	Fluite	Sm58	Long	Sax - Gal
27	Sax	WL e908		
28	V. Gtr	Sm58	Long	Gtr - Nitzan
29	V. KB	Sm58	Long	Yossi - Piano / Mac
30	TB KB	Sm58	Long	
31	V Zohar	Sm58	Long	Gtr - Zohar
32	Shiri	<b>WL Shure UR</b>	Straight	<b>D-Facto2</b>
33	Spare	<b>WL Shure UR 58</b>		<b>UR2 58</b>

Output	Musician	Type	Notes
1-2	Drums (Buki)	Small Mixer	Line in
3-4	Bass (Danny)	WL IEM - G3	Stereo, Vol Boost +6, Limit Off
5-6	Gtr (Nitzan)	WL IEM - G3	Stereo, Vol Boost +6, Limit Off
7-8	Key's (Yossi)	WL IEM - G3	Stereo, Vol Boost +6, Limit Off
9-10	Acc (Zohar)	WL IEM - G3	Stereo, Vol Boost +6, Limit Off
11-12	Sax (Gal)	WL IEM - G3	Stereo, Vol Boost +6, Limit Off
13-14	Shiri Maimon	WL IEM - G3	Stereo, Vol Boost +6, Limit Off
15-16	Shiri Spare	WL IEM - G3	Stereo, Vol Boost +6, Limit Off
17	Drums Shaker/Sub	1*18' \ 2*18'	Buki's Butt
18	Click Direct out	To drums mixer	Line in
19-20	DJ	WL IEM - G3	Stereo, Vol Boost +6, Limit Off
21	Side Fills	2 x Wedges SL & SR	Tripods

Total  
 10 x Sennheiser G3  
 1 x Drums shaker  
 1 x 6 Ch mixer for drums  
 2 x Stage wedges

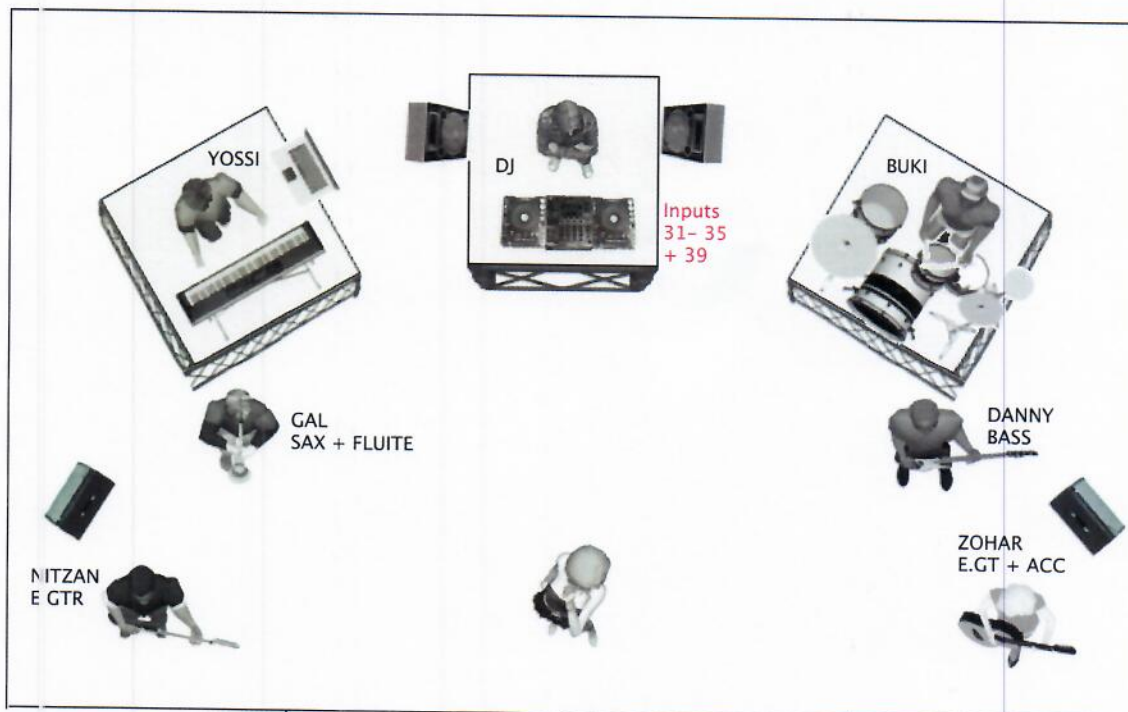

• Yoav Golan, FOH - [yoavgolan7@gmail.com](mailto:yoavgolan7@gmail.com) 0545-984224